

# INGENIOUS IDEAS FOR RETAIL



**When Being Seen  
Means Being Sold™**

- AMT™ ADJUSTABLE  
MERCHANTISING TRAY™ SYSTEM
- EWT™ EXPANDABLE  
WIRE TRAY™ SYSTEM
- WONDERBAR®  
BAR MERCHANTISING SYSTEM



# INGENIOUS IDEAS FOR RETAIL

# AMT™ ADJUSTABLE MERCHANDISING TRAY™



DIVIDER SYSTEM  
MANUAL FEED SYSTEM

## AMT™ Adjustable Merchandising Tray™ System

- Removable tray permits rear loading and encourages proper product rotation.
- Width adjusts easily yet locks with built-in clips.
- Durable, easy to clean, UV protected, freezer and cooler ready and maintenance free.
- Customers use manual feed to access product, facing the shelf or store personnel can manually face the products.
- Organizes product for easy access, allowing customer to see product without removing it from shelf.
- Prevents stacked product from toppling over.
- Easy to add new lanes and items to shelf.
- Improved appearance increases sales, carves out a well-defined shelf space for each variety.
- Smooth, non-porous lubricious material allows effortless flow of product.



## ADJUSTABLE WIDTH



### B Width

Tailored for Yogurt cups and similar products: Adjusts from 2<sup>11</sup>/<sub>16</sub>" to 3<sup>5</sup>/<sub>16</sub>" in 1/<sub>8</sub>" increments. Standard 22" length, breakaway to 20" and 18" length in the field.

## FEATURES:



### Built-in Manual Feed

Quickly and conveniently forwards and faces product, then tucks out of sight into the tray.

## OPTIONS:



### Label/Sign Holders

Optional holders offer a protected home for product and price information, improve product navigation and sales.

## AMT™ ADJUSTABLE MERCHANDISING TRAY

Item No.	Height	Width Adjusts 1/8" Increments	Breakaway Lengths	Pack Trays/KIT	W/ Ctn	1-10 Kits	11-100 Kits	101-500 Kits	501+ Kits
----------	--------	----------------------------------	----------------------	-------------------	-----------	-----------	-------------	--------------	-----------

### Adjustable Merchandising Tray™ Systems

#### Yogurt System (Small)

AMTSMKIT	6 1/2"	2 1/16" to 3 5/16"	22", 20" or 18"	12	16#	\$68.80	\$61.16	\$53.53	\$45.89
----------	--------	--------------------	-----------------	----	-----	---------	---------	---------	---------

Price per Kit

Price per Each

	5.73	5.10	4.46	3.82
--	------	------	------	------

#### Ice Cream System (Large)

AMTLGKIT	6 1/2"	4" to 4 5/8"	22", 20" or 18"	12	18#	75.40	67.03	58.66	50.29
----------	--------	--------------	-----------------	----	-----	-------	-------	-------	-------

Price per Kit

Price per Each

	6.28	5.58	4.89	4.19
--	------	------	------	------

All orders must be for standard kit pack – no splitting of kits permitted. Packed unassembled. Standard color: White tray with clear paddle and clear pull strap. Each tray consists of a left side, a right side, a paddle and pull strip. Paddle and sidewall height extensions are available. Call for information. Each kit contains assembly instructions.

Item No.	Description	Pack	W/ Ctn	1-10 Kits	11-100 Kits	101-500 Kits	501+ Kits
----------	-------------	------	-----------	-----------	-------------	--------------	-----------

#### Clear Label Holder for front of trays above

DBR30-XX-0064-12/bag	1 1/4" x 2 1/2"	12/bag	—	\$11.04	\$ 8.83	\$ 7.73	\$ 6.62
----------------------	-----------------	--------	---	---------	---------	---------	---------

Price per 100

Clear Label Holders are packed in kit in bags of 12, (one per each AMT). Standard color is clear, other colors available. Minimums may apply.

## TWO SIZES



### D Width

Tailored for pint, pint-and-one-half, ice cream and similar containers. Adjusts from 4" to 4 5/8" in 1/8" increments. Standard 22" length, breakaway to 20" and 18" in the field.

## MANUAL FEED, ADJUSTABLE WIDTH, CARRY HANDLES, AIR CIRCULATION



### Adjustable Width

Tailors to a broader range of products, improves look and operation, allows re-use in new plan-o-grams and merchandising. Adjusts in 1/8" increments.



### Built-in Carry Handles

Trays lift out as single unit with easy-grip handles to allow quick re-organizing of product categories, restocking or cleaning.



### Built-in Ventilation

Molded in openings improve refrigeration air circulation.



### Paddle Extension

Available for stability and better forwarding of tall or multi-tier products. Snaps onto paddle.



### Top Tier Sidewall

Available for support and containment of tall or multi-tier products. Snaps onto sidewall.

## LABEL/SIGN HOLDER & FLAGS



### Promotional Flag

Perpendicular flags improve product promotion navigation and sales.



Protected by patents and patents pending.

Built-in manual feed allows trouble-free forwarding and facing of products for increased sales and profit.



Trays lift out as a single unit with easy-grip handles to allow quick restocking of dated product or cleaning of shelves.

Manual Feed allows easy facing of product, yet retracts back into the unit when not needed.

# INGENIOUS IDEAS FOR RETAIL EWT™ EXPANDABLE WIRE TRAY™ SYSTEM



**DIVIDER SYSTEM  
AUTO-FEED SYSTEM  
SHELF OR WALL MOUNT**

Fronts available:

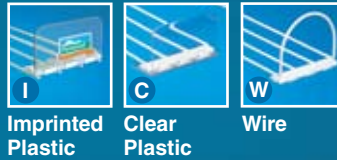

I  
Imprinted  
Plastic

C  
Clear  
Plastic

W  
Wire



## EWT™ Expandable Wire Tray™ System

- Powder-coated galvanized wire with Celcon plastic adaptor blocks, offering economy and long life even in harsh environments. A low-cost metal wire alternative to plastic tray systems.
- Accommodates almost any style/size package.
- The system is manufactured in any lane divider depth you choose to tailor it to your specific needs. Costs are shown for a typical 11" lane divider depth.
- For standard shelving, wire shelving, table top, freezers and coolers.
- Pegboard, slatwall & crossbar versions available.
- Mounts using wire ties, double-sided tape, anti-skid pads or rail system.
- Label can be adhered to pusher for branding or restocking information.
- An economical, adjustable stock system, allowing easy custom configuration when necessary. Open wire design promotes air circulation, sheds dust and dirt. Available in colors.



## FREESTANDING &



I C W

### Single Units

Single units for standard shelf, wire shelf or table top, clear plastic or 4" wire front stop and dividers standard. Freestanding, wire tie, tape or anti-skid pad mounts.

## FEATURES & OPTIONS:



### Adhesive, Pushbutton, Label Holder & Rails

Many rail designs available including low profile adhesive, pushbutton mount, clear product stop, & label holder rails.

## WALL MOUNT:



I C W

### Pegboard, Slatwall, or Crossbar Flat Tray

An inexpensive, wall mount unit that forms a simple ledge or tray without side dividers. Maximum economy. One-piece unit, no assembly required. Crossbar version available, not shown.

## MINI SYSTEM:



W

### Pegboard, Slatwall, or Crossbar Divider Tray

Moveable sides adjust width from 3 to 6", 2" high wire front stop & divider. For 1/4" pegboard & slatwall. Crossbar available. Shipped assembled.

## RAIL MOUNT UNITS: WIRE OR CLEAR PLASTIC FRONT STOP



**Modular Units**  
For standard shelf, wire shelf or table top. Front rail mount only. Modular units are advantageous in displays where the number of facings or size of product changes often.



**Multiple Interlocked Units**  
Functions as single unit, though facing widths are adjustable, 4" wire front stop & divider, clear plastic front available. Front rail, freestanding, wire tie, tape or anti-skid mounts.



**Pegboard or Table Mount Anti-Theft Security Unit**  
Allows only the front-most item to be removed one-at-a-time, preventing mass theft while permitting access to a single item trouble-free.



**Pizza/Oversized Product Units**  
Single units for standard shelf or wire shelf. Dual pushers, dual 4" wire front stops and 7" dividers standard. Free standing, wire tie, tape or anti-skip pad mounts.



**Tiered Units**  
Standard and Security Units can be designed to form a tiered or stacked one-piece display. Tiered units must be designed to accommodate your specific product.

## RAILS, TIE-DOWNS, PRODUCT STOPS, PUSHERS, SPRINGS



**Freestanding, Wire Tie, Tape, or Anti-skid Pad Mount**  
Units may be free standing, wire tied, tape mounted or equipped with anti-skid pads to resist movement.



**Clear, Imprinted or Open Wire Front Product Stops**  
Wire stops provide strength, easy visibility, and air circulation in cooler applications. Clear plastic stops available imprinted.



**Extended Height Paddles**  
Large paddles support tall items. Branding, stocking, and cross selling messages possible via pressure sensitive labels or pad printing. Designed for changeable top-header messages.



**Special Collapsible Pusher Paddles**  
A unique flexible pusher paddle design compresses to permit additional product to be loaded, fully utilizing the full depth of the unit.



**Five Spring Tensions & Ganging Possibilities**  
Five spring tensions are available, plus the unique ability to mount multiple springs per pusher.

## WIRE OR CLEAR PLASTIC FRONT STOP



**Pegboard, Slatwall, or Crossbar Divider Tray**  
Moveable sides adjust width of facing, 2" wire front stop and divider. For 1/4" pegboard and slatwall. Crossbar version available, not shown. Shipped assembled.



**Multiple Interlocked Pegboard/Slatwall/Crossbar**  
Moveable sides adjust width of facing, 2" wire front stop and divider. For 1/4" pegboard and slatwall. Crossbar version available, not shown. Shipped assembled.

## WALL MOUNT OR SHELF/TABLE TOP



**Table Top Mini Divider Tray**  
Moveable sides adjust width from 3 to 6", 2" high wire front stop and divider, clear plastic front rail available. Freestanding, wire tie, tape or anti-skid pad mounts. Shipped assembled.

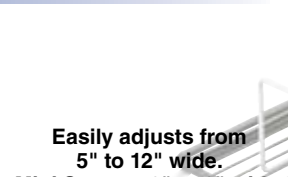

**Easily adjusts from 5" to 12" wide. Mini System 3" to 6" wide.**



**Adaptor mounts in a variety of ways.**

Protected by patents or patents pending.

# INGENIOUS IDEAS FOR RETAIL WONDERBAR® BAR MERCHANDISERS



## TRION® WONDERBAR® MERCHANDISERS

- Multi-purpose for use in coolers, freezers, candy aisle, center store, auto and more.
- Organizes department, enhances shopability.
- Mounts anywhere with Universal Brackets.
- Interchangeable with other bar systems.
- Adds both facings and rows to a display.
- Billboards items, increases sales up to 20%.
- Automatically feeds and faces product.
- Return on investment in as little as 90 days.
- Reduces labor 7-10 hours/week/8-foot section.
- System lifts out for easy rear stocking.
- Insures stock rotation; reduces spoilage.
- 48 facing resets in as little as 15 minutes.

For Freezers, Coolers,  
Dry Goods, Automotive,  
and Center Store

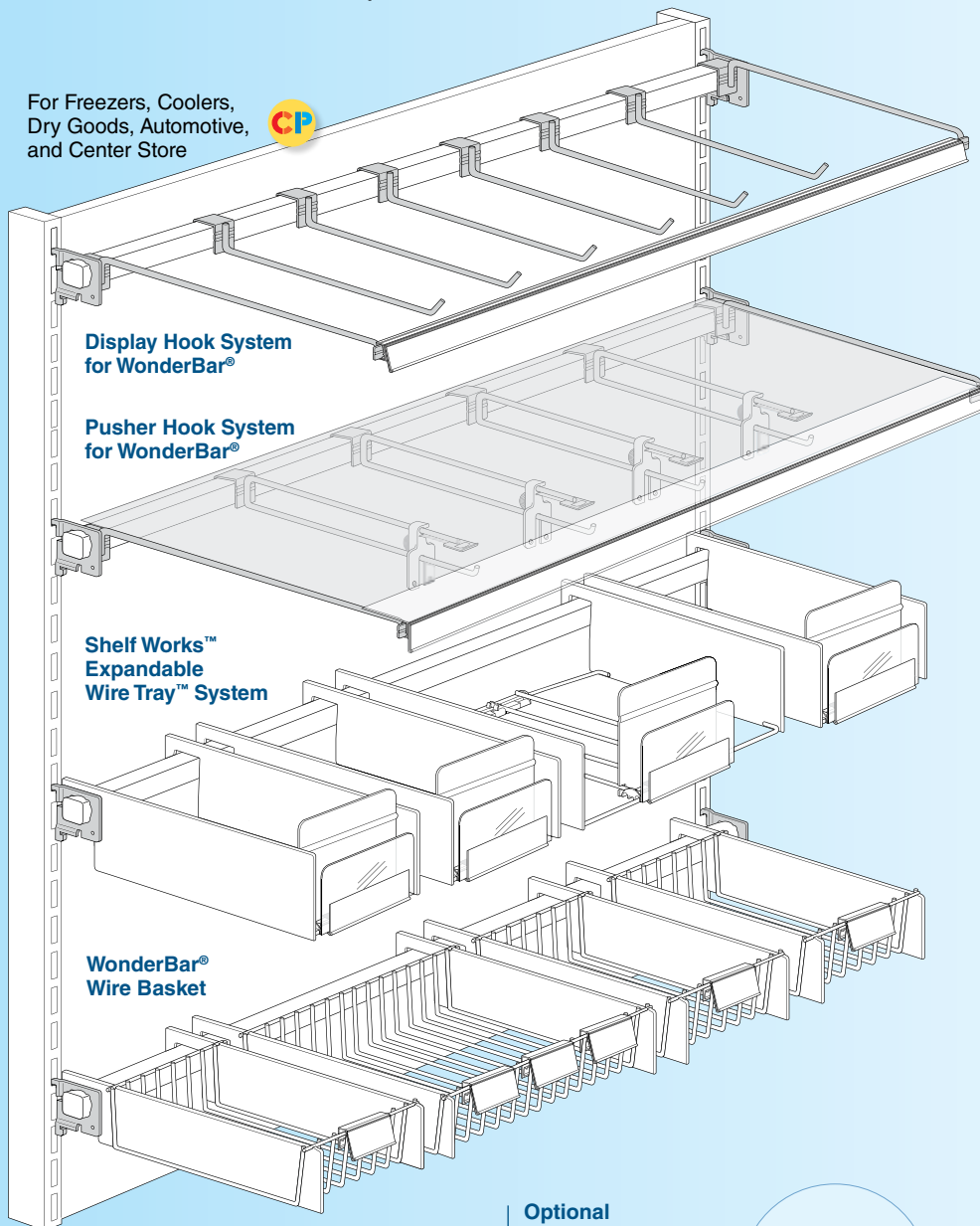

Display Hook System  
for WonderBar®

Pusher Hook System  
for WonderBar®

Shelf Works™  
Expandable  
Wire Tray™ System

WonderBar®  
Wire Basket

Patents and Patents Pending

**Optional  
WonderBar™ Plus**  
Accepts plug-in  
style hooks in a  
variety of lengths.

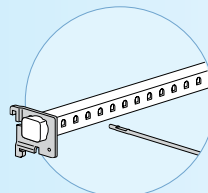

### Simple, No Tools Installation

Fits all types of gondola upright including both thick- and thin-walled gondola uprights.



### Square Bar

Less expensive than traditional rectangular bar, yet carries the same load.

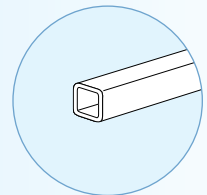

### Clear Scan® AdjustaView® Label System

AdjustaView® available to run across the front of the display. Can be angled at -15°, 0°, or +15° to vertical. A range of label holder sizes are available to satisfy any labeling need.

#### Adjustable Front Angle

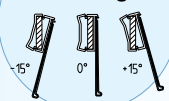

### Air Flow Baffle

The Air Flow Baffle is used in open coolers to direct cold air to the front of the cabinet where product temperatures can be troublesome.

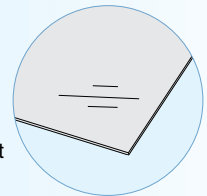

### Shelf Works™ Expandable Wire Tray™ System

Shelf Works™ EWT™ Shelf Management System adjusts easily from 5 1/2" to 10" wide (or mini system 3 3/8" to 6 1/2" wide) and is available in a range of depths. EWT is well suited for almost any product size and package style from boxes and bags, to tubs, blister packs and clamshells.

#### Adjustable Width EWT

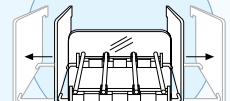

### WonderBar® Wire Basket

Three inch deep baskets are available 6" and 12" wide and in 3 depths from 17" to 21" to complement WonderBar EWT™.

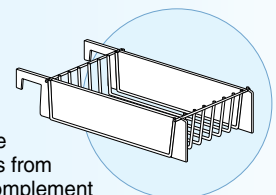

### WonderBar® Square Cross Bar Tube

Standard-size, heavy-duty 1" Square Cross Bar Tube mounts with Universal Brackets (provided) to most gondola and uprights in coolers, freezers, dry goods areas, and on standard gondola center store. ColorPerm® powder coating resists the effects of harsh environments. Standard powder coat colors are White, Black and Beige. Available in 30", 36" and 48" lengths.

### Display Hook System for WonderBar®

Saddle mount, heavy-duty 0.283" (1 gauge) diameter wire hooks are available in 12", 14" and 16" lengths and are capable of withstanding heavy loads and harsh environments including coolers and freezers. Standard powder coat colors are White, Black and Beige.

### Clear Scan® AdjustaView® Label System

AdjustaView® Labeling option is available to run across the front of the display including both Display and Pusher Hook areas. AdjustaView® accepts economical plain-paper labels and can be angled at -15°, 0°, or +15° to vertical for optimal viewing. Available in 30", 36" and 48" lengths, and 30mm and 39mm label holder heights. AdjustaView® Arms are 0.283" wire available in 12", 14, and 16" lengths, as L-front left- and right-hand mount pairs or T-front center arms. Standard powder coat colors are White, Black and Beige.

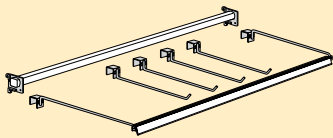
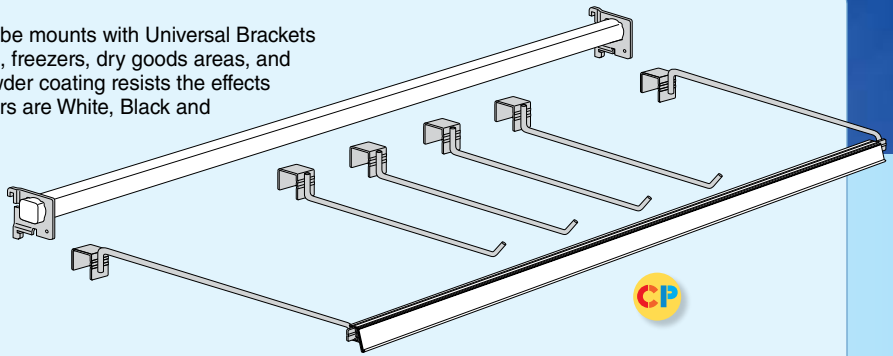

### WonderBar® Kit – TRWB48KIT 1-U

- 1 – Square Bar WONDERBAR48BK
- 8 – Hooks WBRL14CPBK
- 1 – Label Holder Arm Set WBSCAN14 SET-BK
- 1 – Label Holder PPV-30-BK-1219

**\$20<sup>77</sup>**  
As Low As

Typical price  
**\$31<sup>16</sup>** per kit in  
quantities up to 100.

Standard color for kit is Black with Black Label Holder, other colors available. Minimums may apply.

### Pusher Hook System for WonderBar®

Saddle mount, heavy-duty 0.283" (1 gauge) wire hooks are available in 12", 14" and 16" lengths and are capable of withstanding heavy loads and harsh environments including coolers and freezers. Spring loaded pushers keep product forwarded, well faced and promote sales. Standard powder coat colors are White and Black.

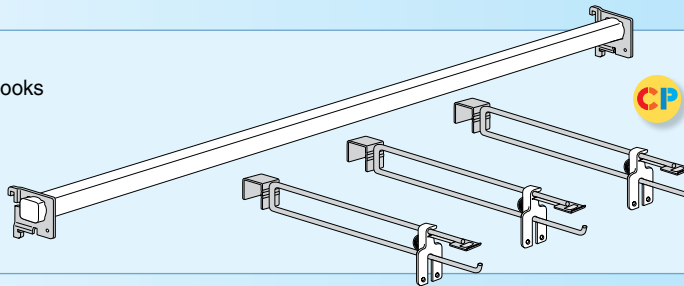

### Shelf Works® Expandable Wire Tray™ System

Shelf Works® EWT™ eliminates the need for standard shelves, allows easy lane width adjustment from 5½" to 10" wide (or mini system 3⅜" to 6½" wide) and is well suited for almost any product size and package style from boxes and bags, to tubs, blister packs and clamshells. EWT™ lifts out for easy restocking and product rotation and is available in 5 depths from 17" to 24". Optional accessories include individual product lane Label Holders and oversized clear product stops for specific applications. Standard powder coat colors are White, Black and Beige.

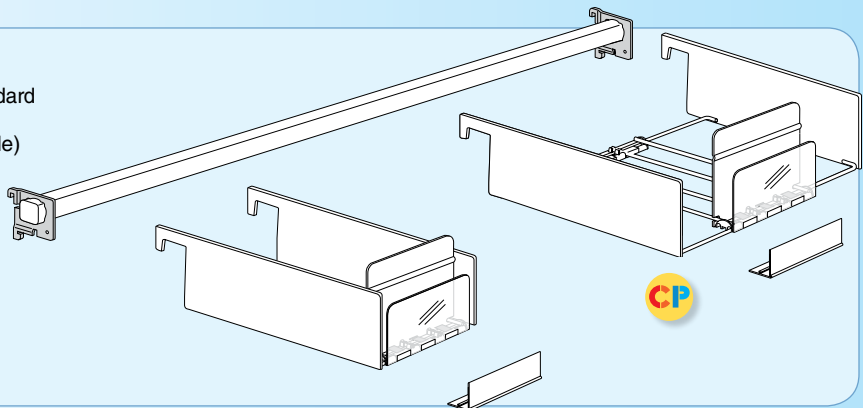

### WonderBar® Wire Basket

Three inch deep baskets are available 6" and 12" wide and in 3 depths from 17" to 21" to complement WonderBar EWT™. Optional 1¼" x 3" label holders. Wire Baskets are suitable for small, random or unusual shape items (samplers, single serve packs, etc), horizontal cylinder shapes (meats, cheeses, biscuits, cookie dough, etc), informal "dump bin" style presentations, and lift out for easy restocking. Standard powder coat colors are White, Black and Beige.

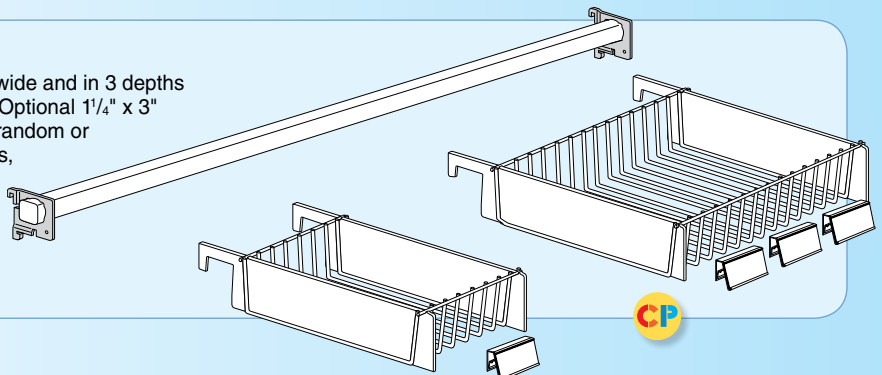



An American Manufacturing Company

Trion Industries, Inc. 297 Laird Street Wilkes-Barre, PA 18702-6997  
Toll-Free 1.800.444.4665 Phone 570.824.1000 Fax 570.823.4080  
E-MAIL [info@triononline.com](mailto:info@triononline.com) WEB [www.triononline.com](http://www.triononline.com)

## **Display & Scan Hooks**

The World's Leading Manufacturer of Display & Scan Hooks

## **Clear Scan® Label Holder Systems**

Shelf Edge & Storewide Plain-Paper Labeling Systems

## **Shelf Works™ Shelf Management**

Divider & Pusher Systems for Center Store, Coolers & Freezers

## **Anti-Theft Fixtures**

Hook, Shelf & Wall Mount Security Fixtures

## **Cooler/Freezer Merchandising Systems**

Bar Merchandisers, Cooler Labeling, Signing & Shelf Management Systems

## **Bar Merchandisers**

Flat Bar, Square Bar and Rectangular Bar Merchandisers

## **Sign Systems**

Complete, Versatile Sign Solutions



A·R·E | Association for  
Retail Environments



Printed on recycled paper. © 2008 Trion Industries Inc. Wilkes-Barre, PA 18702 01/09